

HIGH TEMPERATURE CAMERA

M530™

*Lynx High Temperature
Color Camera Series*

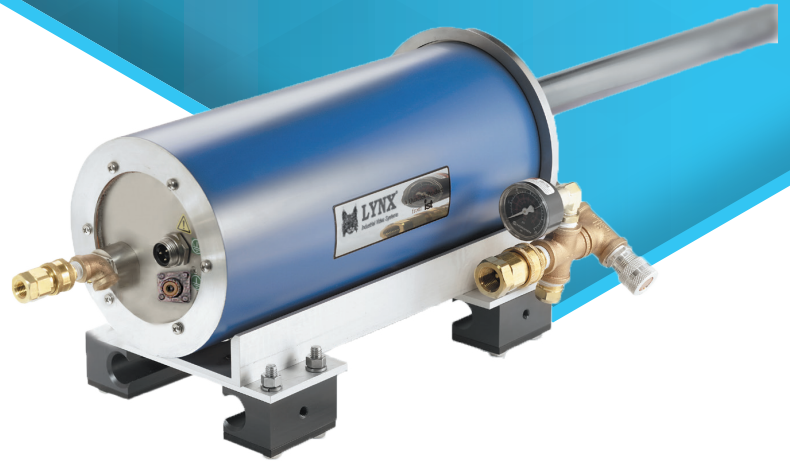

FEATURES

- **Rotary Kilns and Coolers**
Provide continuous product quality monitoring. Observe ring formation, burner flame and product as it moves down the kiln or cooler. See potential upsets early.
- **Coal Fired Utility Boilers**
Monitor flame shape to adjust burners for maximum combustion and minimum fuel usage.
- **Bark Fired Boiler**
Observe fuel distribution, bed and feeder monitoring, combustion and flame characteristics.
- **Glass Melt Tanks**
View for flame impingement and monitor the crown for dripping. Easily see batch load, flow pattern and any unmelted surface material.

DESCRIPTION

The IST-Quadtek™ M530 Series of Visible Light High-Temperature Color Cameras is designed to give you the flexibility to customize electronics, lenses, filters and other options to provide continuous monitoring of your high-temperature internal processes. Straight, oblique, or right angle lens tube options are available that offer more flexibility in mounting the camera. Add a M721™ Remote Auto Iris Controller to adjust the camera iris from the comfort of the control room providing a clear picture from start-up to full load.

SPECIFICATIONS AND PERFORMANCE

Camera	
Power Requirements	85-265 V ac, 47-440 Hz
Camera Detector	1/2 in. solid state color image sensor
System Resolution	>450 lines
Video	1.0 V p-p, 75 ohm, CCTV signal /VTN: RS170-NTSC or /VTP: CCIR-B-PAL video timing
Control	/AIN: Manual focus and iris adjustment on back /AIR: Remote iris adjustment with M721 Remote Auto Iris Controller

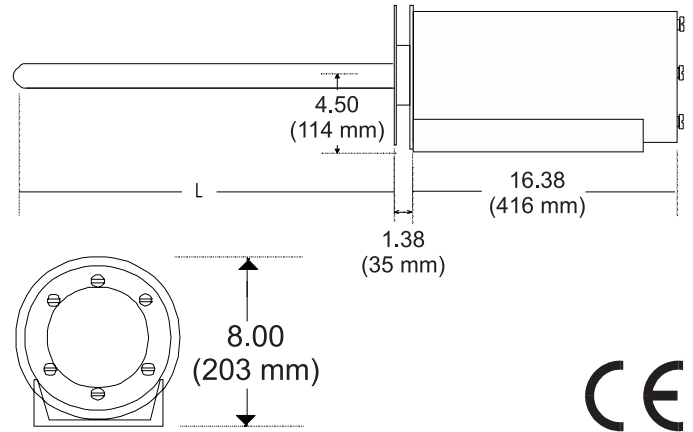

Lens	
Construction	Air or water cooled 304 stainless steel outer shroud. Sapphire window for maximum environmental protection.
Lens Options	/L: Straight view, /RAL: right angle with 90° offset optics, /OAL: oblique angle with 45° offset optics, /WCL: water cooled
Lengths	STD /L30: L=27.7 in. (704 mm) or /OAL30: L=26.7 in. (678 mm) Other lenses available. Please contact your sales representative.
Field of View	Wide: 75 °H x 56 °V Medium: 60 °H x 45 °V Narrow: 35 °H x 26 °V
Diameter	/L: 38 mm (1.5 in.) /RAL & /OAL: 51 mm (2.0 in.) /WCL: 57 mm (2.25 in.)
Cooling Requirements	Instrument quality air, 12-19 dm ³ /sec (25-40 SCFM) @ 5-15 psig (34-103 kPa) required for straight view lens (to ISO 8573-1, Class 1.7.2)
Environment	1621 °C (2950 °F) with proper cooling
Thermocouple	/TJ: Type J thermocouple option /TK: Type K thermocouple option

Enclosure	
Construction	/CEI: Corrosion-resistant, insulated, air-cooled, NEMA 4; /CEW: Corrosion-resistant, water-cooled, NEMA 4
Cooling Type	/CCP: Air purged with check valve, 1 SCFM @ 2 PSI (0.5 dm ³ /sec @ 14 kPa) /CCV: Vortex cooling 13 dm ³ /sec @ 690 kPa (25 SCFM @ 100 PSI); Instrument quality air required
Ambient Environment	Max. 60 °C (140 °F) with negligible radiant heat load. Water cooled option available to handle high radiant heat environment

Mechanical	
Video Output Jack	Female PL-259 "UHF" type
Power Input Jack	Removable waterproof miniplug (JOY type TP, female 3-conductor; mating power cord provided)
Enclosure Cooling Input	1/4 in. brass quick-disconnect nipple; mating coupler (Snaptite BVHC4-4F) provided
Lens Cooling Input	1/2 in. brass quick-disconnect nipple; mating coupler (Snaptite BVHC8-8F) provided
Weight	14 kg (30 lb) for air-cooled configuration (lens and camera)

SPC-150-EN-A_DMD-08/2021

Copyright © 2021 Mirion Technologies, Inc. or its affiliates. All rights reserved. Mirion, the Mirion logo, and other trade names of Mirion products listed herein are registered trademarks or trademarks of Mirion Technologies, Inc. or its affiliates in the United States and other countries. Third party trademarks mentioned are the property of their respective owners.

Specifications may vary according to system configuration. We reserve the right to modify or amend the information herein without prior warning. Please contact your Mirion representative for further information.

Mirion Technologies (IST) Ltd and Mirion Technologies (Imaging), LLC are ISO 9001:2015 certified companies (certificates available on request or at www.mirion.com).

Please note that the products and accessories described in this data sheet may be subject to UK export control or US re-export control. Please check with your authorized representative when enquiring about this product.

Per maggiori informazioni contattare:



Via Bizet, 44
20092 Cinisello Balsamo (MI)
Tel. 02 - 66.59.59.77
e-mail: infrared@inprotec-irt.it
web: www.inprotec-irt.it



www.mirion.com